

**Hawaiian
Electric**

The information found in this document are general guidelines that may be used to aid in the preparation of your service request proposal. Please be advised that depending on the specific needs and actual conditions of your project, Hawaiian Electric may require your design to comply with different specifications including specifications that include more stringent requirements than those included in these design specification guidelines. For further guidance and clarification on the actual specifications that will apply to your particular project, please refer to instructions issued by Hawaiian Electric's Planner or Engineer who is assigned to your particular (Project/Review Request/...). Additionally, please be advised that Hawaiian Electric reserves the right to require additional modifications to any approved design if it is determined during actual construction that additional modifications must be made to address certain field conditions that were not detected or Hawaiian Electric was unaware of during the design review process.

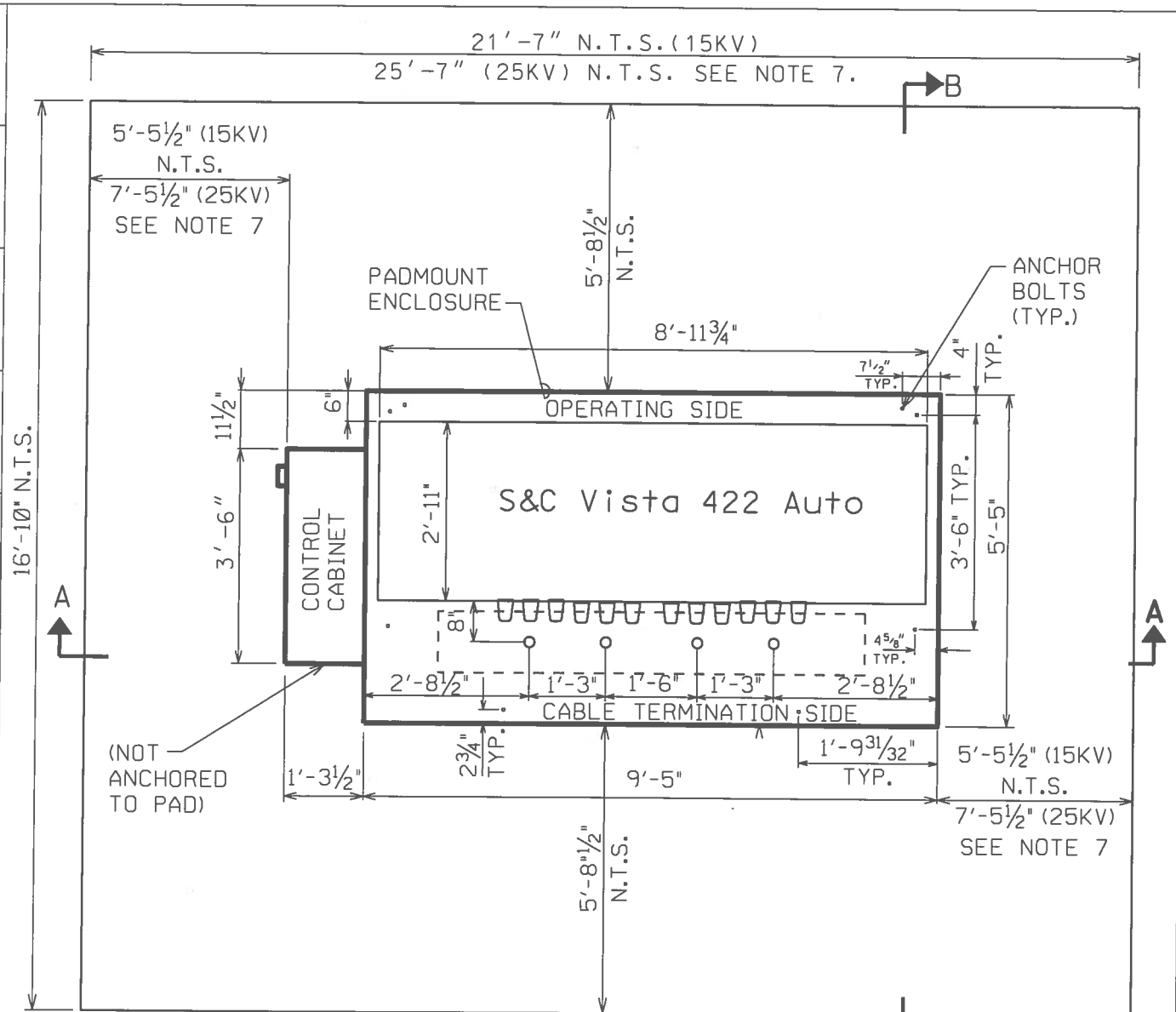



PLAN

NOTES:

1. CONCRETE COMPRESSIVE STRENGTH: 3000 PSI IN 28 DAYS.
2. REINFORCING: CLEAN AND NEW ROUND DEFORMED BARS (ASTM A615, GRADE 60) AND GALVANIZED 6 x 6 W1.4 x W1.4 WELDED WIRE FABRIC.
3. TOP OF CONCRETE PAD TO BE SMOOTH AND TRUE. OTHER EXPOSED SURFACES TO BE SMOOTH AND FREE FROM DEFECTS.
4. CONSTRUCTION TO COMPLY WITH AMERICAN CONCRETE INSTITUTE (ACI) 318 AS AMENDED.
5. WEIGHT OF SWITCHGEAR EQUALS 2400 POUNDS.
6. REFER TO STD. 30-1001 FOR CONDUIT SIZES.
7. IF SWITCHGEAR TO BE ENERGIZED AT 15KV (MAX) ONLY, REQUIRED CLEAR SPACE IS 21'-7" X 16'-10"
IF SWITCHGEAR TO BE ENERGIZED AT 25KV, IMMEDIATELY OR IN THE FUTURE, REQUIRED CLEAR SPACE IS 25'-7" X 16'-10"
8. ROUTE OUTGOING FEEDERS THROUGH NEARBY HANDHOLE TO FACILITATE FUTURE CHANGE OUT TO SCADA READY SWITCHGEAR.

| | | |
|----------|-------|---------|
| REVISION | DATE | INITIAL |
| | 03-15 | AP HH |

| | | | | | | | |
|--|----|----------|-----|--|-------------|----------|----------|
| DRAWN | CT | DESIGNED | RRT | APPD | L. Miyahara | REDRAWN | |
| SUPERSEDES | | | | CONCRETE PAD INSTALLATION WITHOUT SIDEWALK | | ORIGINAL | 07-2012 |
| ENGINEERING STANDARD HAWAIIAN ELECTRIC CO. INC. | | | | S&C VISTA 422 AUTO TRANS. SWGR. UG DUCTS AND STRUCTURES 15KV/25KV | | | REV 1 |
| | | | | | | SHEET | 1 of 2 |

IP_PWP:dms04781\pst305710_01.dgn
apomales
20-JAN-2015 10:23

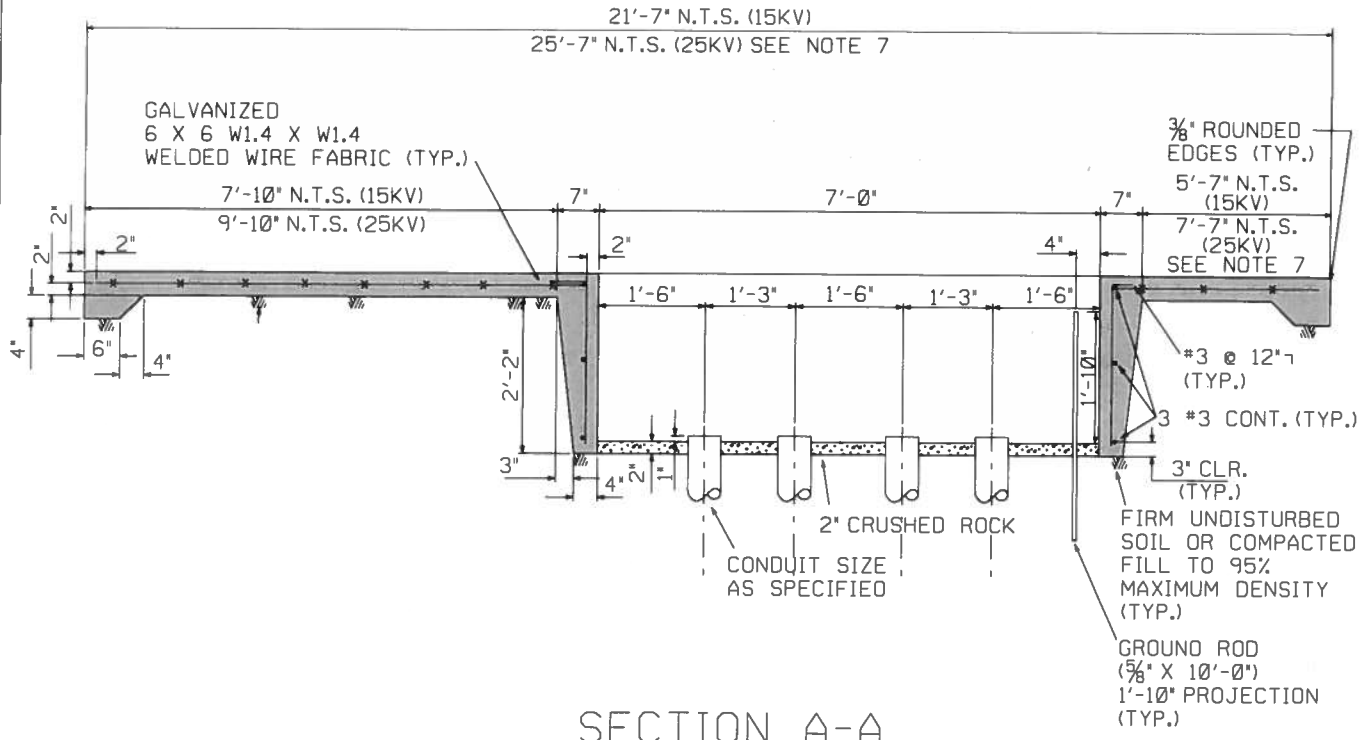

SECTION A-A

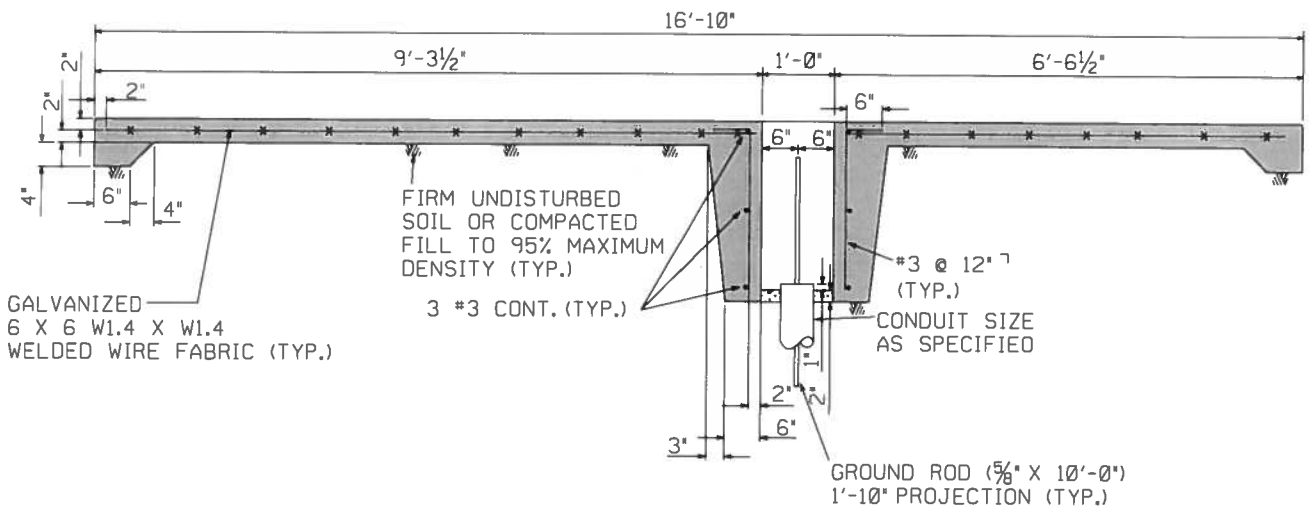

SECTION B-B

| | |
|----------|-----------|
| DATE | 03-15 |
| INITIAL | AP HH WJH |
| REVISION | |

| | | | | | | | |
|--|----|----------|-----|--|-------------|----------|----------|
| DRAWN | CT | DESIGNED | RRT | APPD | L. Miyahara | REDRAWN | |
| SUPERSEDES | | | | CONCRETE PAD INSTALLATION WITHOUT SIDEWALK S&C TYPE VISTA AUTO TRANS. SWGR. UG DUCTS AND STRUCTURES 15KV/25KV | | ORIGINAL | 07-2012 |
| ENGINEERING STANDARD HAWAIIAN ELECTRIC CO. INC. | | | | | | | REV 1 |
| | | | | | | SHEET | 2 of 2 |

IP_PWP-dms04781\pst305710_02.dgn
opomales
20-JAN-2015 10:23